

DESIGN | ENGINEERING | CONSTRUCTION

# WATER SHAPES

Exploring the Art and Science of Water

July 8, 2021

[watershapes.com](http://watershapes.com)

## Featuring



## The Life of Streams

Streams are about movement, journeys and experience. They create connections within the landscape and they even tell stories. As Anthony Archer Wills explains, designing and building streams is a form of watershaping that is best realized when based on keen understandings of nature, narrative and motion.

[CONTINUE READING](#)





## The Buzz About Bees

Scott Cohen is passionate about plants and especially those that produce beautiful flowers. Here he explains that while plants add a rich dimension to his designs, they do also attract pollinators, including bees, other insects, hummingbirds and even bats. It is impossible to have one without the other, but to his mind, having a garden blossoming with color and life is a source of tremendous joy and fascination.

[CONTINUE READING](#)

**TWINSCAPE**  
REINVENT THE ART OF SPACE  
**HYDRO FLOORS**



## BENEATH THE SURFACE

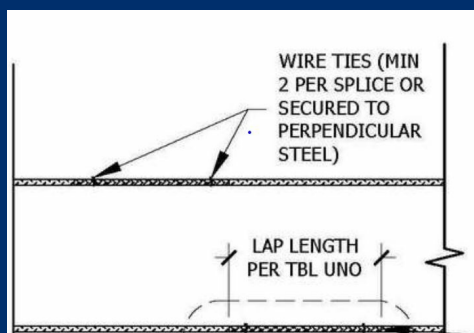

### Detail S032B: No Shotcrete Shadows

Reliable concrete structures are critical for a variety of reasons. Avoiding 'shadowing' in the shotcrete-placement process is crucial to the structural integrity of pool shells, notes Dave Peterson. Here, he shares a detail that avoids the voids that can lead to structural failure.

[CONTINUE READING](#)



# WATERSHAPES WORLD BLOG

## Transporting Water

In his recent feature, "Defeating Drought," Eric Herman sought to provoke an important conversation about the future of water supplies in areas prone to shortages. As the reservoir levels continue to drop in the western U.S., one builder offers his view on a path, or more accurately a pipeline, that he believes we should follow.

[CONTINUE READING](#)



## DIRECT CONNECTIONS

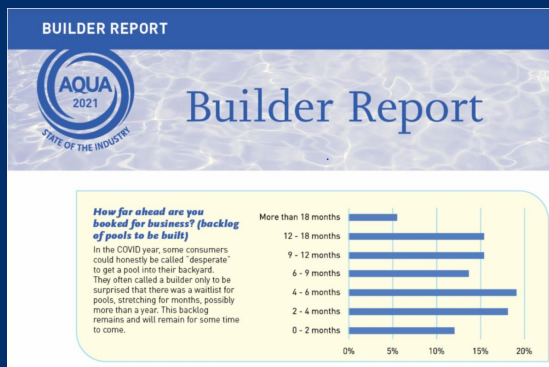

### Surveying Builders

It's been a wild ride for pool builders. Back on June 30<sup>th</sup>, Watershape University presented a special edition of *Wolfpack Webinar Wednesdays*. Scott Webb, executive editor of *AQUA Magazine* and host Eric Herman dove into AQUA's annual Builder's Survey. In addition to their snappy analysis, Webb and Herman unpack question about the current labor shortage, supply lines and overheated consumer demand.

[CLICK HERE TO WATCH](#)

# OPEN WATERS

## Seeds of Integrity

Effective branding and marketing start with who you are and the values that define you, says Kurt Kraisinger, and as he points out in this incisive diatribe on success, there are no short cuts to integrity. It's the basis of everything you do.

[CONTINUE READING](#)

VERSATILE POOL CONTROL WITH  
UNMATCHED VALUE.



**HAYWARD**  
We Build Better.™

[Explore OmniPL™ >>](#)

## WOLF PACK CORNER



## Taking a July Break

Watershape University is currently observing a summer break during July. We'll return in early August with a full schedule of *Wolfpack Webinar Wednesdays* and a series of exciting news about upcoming educational opportunities. Plus, we'll be introducing our new student portal that will offer a convenient way to take advantage of the Wolfpack's variety of programs. We'll see you soon.

## Print Archive

### October 1999 (Vol. 1, No. 5)

In late 1999, the magazine was hitting its stride covering a breadth of topics from leading industry voices. The fifth issue was a true tour de force, featuring Mark Holden on aquatic design history, Jon Mitovich on dry-deck fountains, Curt Straub on conflict resolution and David Tisherman on site geometry.

[READ IT HERE](#)

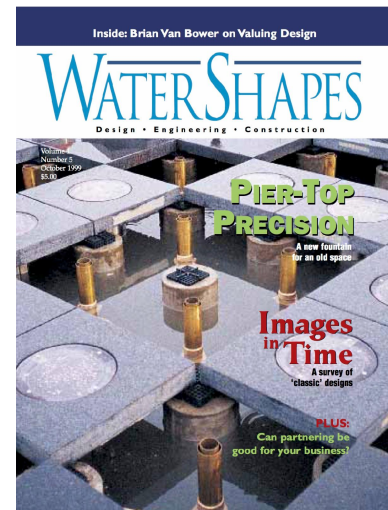

## THE WATERSHAPES WEB CAFE

We Browse So You Don't Have To!



### ***Glamour Magazine Promotes Swimming Health Benefits***

The iconic fashion magazine describes the multi-faceted and profound benefits of taking a dip. From the physical to the psychological, it's the best physical activity for overall wellness.

*It's why everyone should go for a swim.*

**CONTINUE READING**

---

### ***Modern Pools from Architectural Digest***

As contemporary design continues to dominate the custom housing market, *AD* opens its archives with an eye toward harmonizing watershapes with modern architecture.

*Clean lines and geometry can make powerful visual statements.*

**CONTINUE READING**

A horizontal banner for Pentair. On the left is the Pentair logo, a stylized diamond shape with a grid pattern. To its right is the text "PENTAIR" in white. Further right, the text "TOOLS TO GROW YOUR BUSINESS. FOR LIFE." is displayed in white. On the far right, there is a green button with the text "LEARN MORE" in white. The background of the banner shows a swimming pool at night with lights reflecting on the water.

## **ON TAP**

Learn About the Latest Products in Market



## VGB-Compliant Drains from AquaStar

AquaStar (Ventura, Calif.) manufactures a complete line of anti-entrapment suction outlets made to VGB-certified specifications. All components meet or exceed ANSI/APSP 16-2011 and NSF/ANSI 50 2009a national standards and ASTM G154 UV testing exposure. Sumps are manufactured from strong PVC, drain covers are manufactured from UV resistant polymers.

[CONTINUE READING](#)

## Pentair's Commercial UV System

Pentair (Cary, N.C.) makes the BioShield Commercial UV disinfection system, designed to eliminate problems with waterborne pathogens and chloramine formation. The system is made of Schedule 80 solvent-welded PVC, available in standard sizes up to 2,335 gpm and are NSF 50 certified. The low-pressure, high-output UV lamps offer up to 12,000 hours of continuous operation.

[CONTINUE READING](#)

## Corporate Engagement Teammates

Watershape University appreciates the support of the following industry leaders:



[Trouble Viewing this email? View as a Webpage here.](#)

